

DATA	18.02.2019
CUSTOMER	
REFERENCE	

<b>Evaporator Model</b>		<b>SCE 73 - 4P</b>
Number of refrigerant circuits		1
Requested capacity	kW	72
Margin of surface	%	0,0
PED category		---

<b>INPUT DATA</b>		<b>TUBES SIDE</b>	<b>SHELL SIDE</b>
<b>Refrigerant</b>		R22	
Evaporating Temperature	°C	2	
Evaporating Pressure	bar A	5,312	
Superheating	K	5	
Condensing Temperature	°C	40	
Condensing Pressure	bar A	15,336	
Subcooling	K	5	
Pressure drop	kPa	28	
<b>Fluid</b>			WATER
Inlet Temperature	°C		12
Outlet Temperature	°C		7
Flow rate	m <sup>3</sup> /h		12,4
Pressure drop	kPa		48
Fouling factor	(m <sup>2</sup> K)/W		0,000043
Velocity (Inside)	m/s	12,94	1,33
Exchange coefficient	W/(m <sup>2</sup> K)	6745	6972
DTML	°C		7,21

**WARNING**

No warnings

**DIMENSIONS**

Surface	m <sup>2</sup>	---	4,09
Weight	kg		70
Total volume	dm <sup>3</sup>	8	17
Overall length	mm		1420
Shell diameter	mm		168
In/out connections	Gas/mm	22 / 42	2"1/2

**OFFER**

Unit net price	Euro	
----------------	------	--

**NOTES**

--

DATA	18.02.2019
CUSTOMER	
REFERENCE	

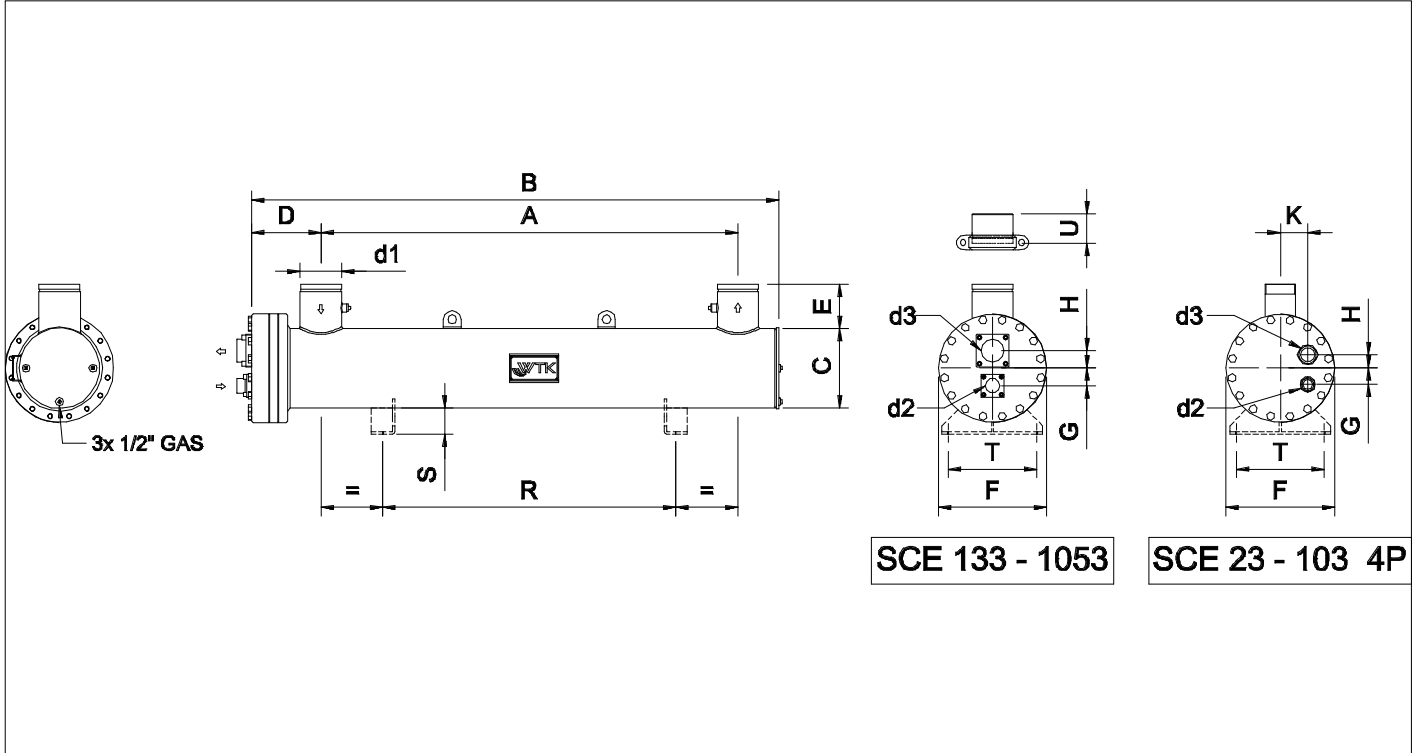
**DRAWING**

**DIMENSIONS (mm)**
**DATA**

Dimension	Value	Code	Value	Description	Unit	Value
A	1180	L	0	Surface	m?	4,09
B	1420	M	0	Weight	kg	70
C	168	N	0	Tubes volume (Refrig.)	dm?	8
D	156	O	0	Shell volume (Fluid)	dm?	17
E	130	R	950	Refrig. connections In/Out	mm	22 / 42
F	245	S	60	Shell connections	Gas/mm	2"1/2
G	45	T	160			
H	37	U	N/A			
K	30	X	0			

This software is only to be used as an assistance and does not replace the necessary specialist knowledge and experience when designing heat exchangers. We continuously work in order to improve and correct the software. Nevertheless we cannot guarantee its absolute infallibility. Therefore the use of the program is at the user's risk.