

Data sheets

Semi-hermetic compact compressors > CXW series - Vi 2.3 low compression ratio / for HFC - HCFC - HFO

Technical data:		
Rotors	#	2
Displacement @ 50 Hz	m ³ /h [50Hz]	468
Displacement @ 60 Hz	m ³ /h [60Hz]	562
Compressor version[1]		2
Motor power (HP)		125
Motor power (kW)		95
Motor voltage at 50 Hz[2]	V/ph/Hz	400 (+/-10%) V/3/50Hz PWS
Motor voltage at 60 Hz[2]	V/ph/Hz	460 (+/-10%) V/3/60Hz PWS
PWS partition		50-50
Capacity control (CC) step	%	100-75-50-25
Capacity control (CC) stepless	%	100-50
MRA, maximum operating current at 400V/50Hz and 460V/60Hz	A	219
LRA, maximum starting current at 400V/50Hz and 460V/60Hz, PWS motor	A	530
LRA, maximum starting current at 400V/50Hz and 460V/60Hz, PWS motor with DOL connection	A	838
Max power consumption	kW [@ 50Hz]	131.2
Frequency min	Hz	30
Frequency max[3]	Hz	70
Protection device		INT69 FRYL Diagnose
Enclosure class		IP65
Maximum pressure HP	bar	30
Maximum pressure LP	bar	20.5
Oil type[4]		POE 170 cSt
Oil charge	l	19
Oil filter		Standard; replaceable
Crankcase heater		Standard; integrate
Oil level sight glass		2
Oil water cooling		Standard
Integrated check valve		Standard
Maximum oil temperature sensor		Standard
Suction plug (SL) mm	mm	104
Suction plug (SL) inch	inch	4" 1/8
Discharge valve (DV) mm	mm	DN80
Discharge valve DV inch	inch	DN80
Net weight	kg	840
Length	mm	1533
Max Width	mm	588
Maximum height	mm	764
Sound power level (5/50, R407A)[5]	dB(A)	92.3
Sound pressure level @ 1m (5/50, R407A)[5]	dB(A)	84.3
Compressor body material		Cast Iron

[1] Motor version: 1, high and middle temperature, all refrigerants; 2, low and middle temperature, all refrigerants; 3 ECOinside, low temperature, only R134a and R1234ze

[2] Other available on request

[3] Maximum frequency depends from the working condition: see FSS3 (Frascold selection software)

[4] Different kind of oil available on request

[5] Sound pressure in free-field, semi-spherical emission, at 1 meter of distance, at 50Hz; power and pressure levels in different condition are available on FSS2

Data sheets

Semi-hermetic compact compressors > CXW series - Vi 2.3 low compression ratio / for HFC - HCFC - HFO

Accessories:	
DOL bridge bars	T00WK1200
Suction valve	T00SK103920B
Optoelectronic oil level switch	T00WP253
Filter clogging switch	T00W3501122
Motor cooling by means of suction gas	T00WK1400
Valve+muffler for ECO/liquid injection	T00WK1500
Rubber vibration absorber kit	T00SK205200
Oil separator	See if You need and the selection on FSS
Nipples for oil cooler connection	T00WK1450

Data sheets

Semi-hermetic compact compressors > CXW series - Vi 2.3 low compression ratio / for HFC - HCFC - HFO

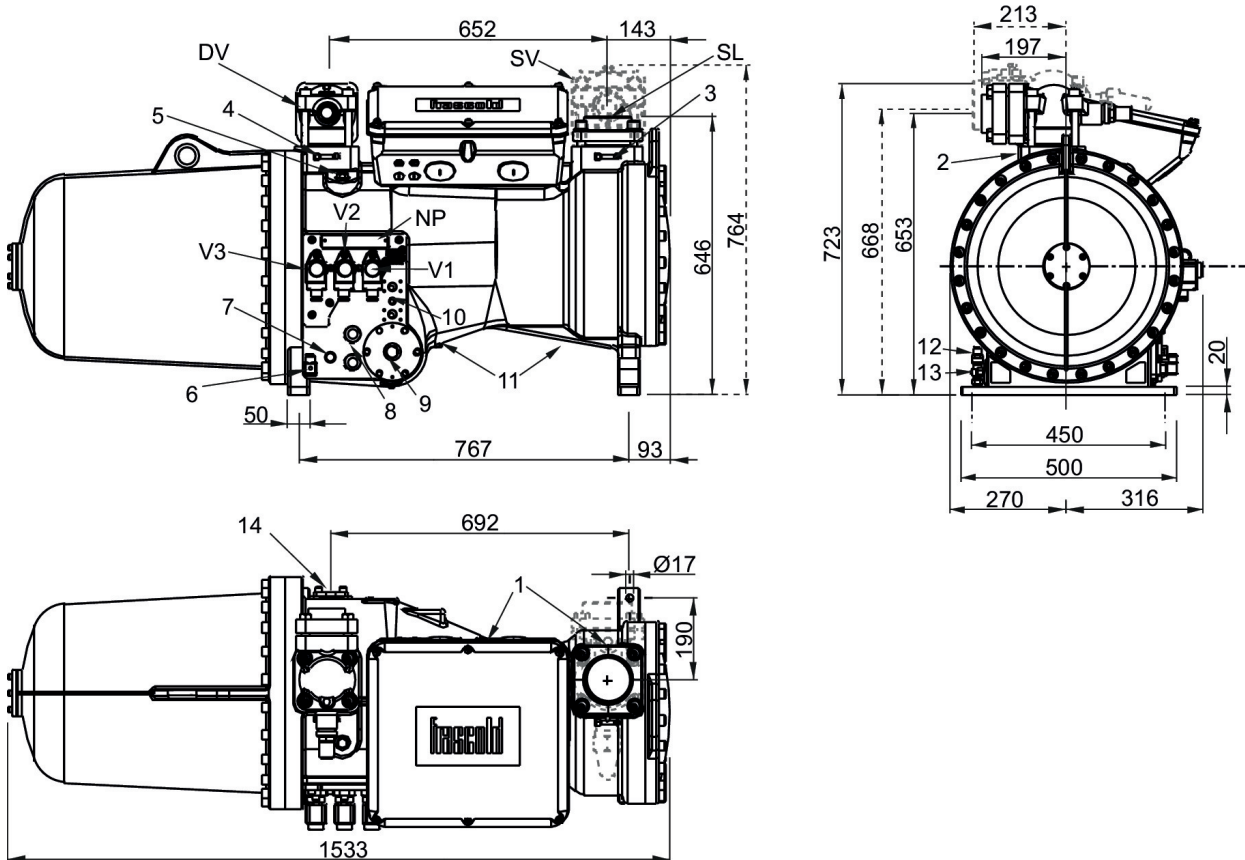

Dimensional drawing:

1	Low pressure connection	1/8" NPT
2	High pressure connection	1/8" NPT
3	Low pressure connection	1/4"SAE x 1/4"SAE
4	High pressure connection	1/4"SAE x 1/4"SAE
5	Oil charge plug	3/8"GAS
6	Crankcase heater	-
7	Oil level switch connection	3/4"NPT
8	Oil level sight glass	-
9	Connection for filter clogging sensor	1/2"GAS
10	Connection for oil cooler	1/2"NPT
11	Connection for oil drain	1/4"NPT
12	Oil drain valve	1/8" NPT
13	Maximum oil temperature sensor	-
14	Connection for ECO/liquid injection	Ø1"1/8
V1	Capacity control valve (step 1)	-

V2	Capacity control valve (step 2)	-
V3	Capacity control valve (step 3)	-
SV	Suction valve	104mm - 4"1/8
SL	Suction plug	-
DV	Discharge valve	79.4mm - 3"1/8
NP	Name plate	-